

Power vacuum pumps - BCVIP4 and BCVIP8

A pneumatic ejector makes it possible to suck in air or any other gas contained in a closed chamber, in order to reduce the pressure. In the medical field, it is used at low working pressure (3.5 Bar). BCVIP ejectors are often used for handling materials or clamping small parts. They can be used with several suction cups. The flow rate of the BCVIP ejectors is high and the pressure is less sensitive to wear on the suction cup.



BCVIP4 et BCVIP8

Characteristics

Models	Air consumption	Max vacuum at 4 bar	Max vacuum flow	Working temperature	Noise level	Weight	Dimensions		
	(L/min)						(%)	(L/min)	(°C)
BCVIP4	63	90	165	-20°C to +100°C	65 db	670	182	67	32
BCVIP8	126		320						

Materials

Epoxy painted AL, brass, silicon rub, neoprene, stainless steel.

Options

- Air silencer FFS 1/2"
- Kit energy saving pneumatic and electric 1/4"

Time in sec for evacuation of 1 lit to vac' level

Vacuum (bar)	0,1	0,2	0,3	0,4	0,5	0,6	0,7	0,9
BCVIP4	0,046	0,16	0,36	0,7	1,2	2	2,8	18
BCVIP8	0,023	0,08	0,18	0,35	0,6	1	1,5	9

Drawing BCVIP4 and BCVIP8 (mm)

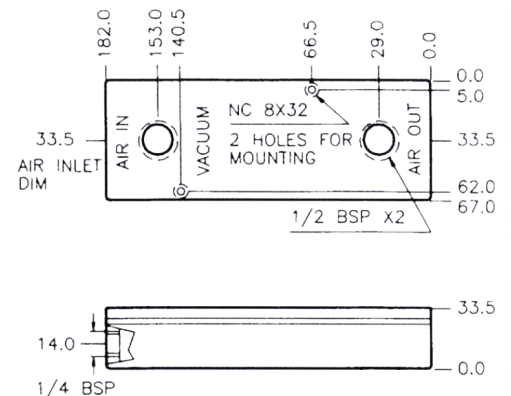

Induced air in lit per min

Vacuum (bar)	0	0,1	0,2	0,3	0,4	0,6	0,8
BCVIP4	165	88	51	24	18	9	3
BCVIP8	320	176	102	48	36	18	6

Data curves

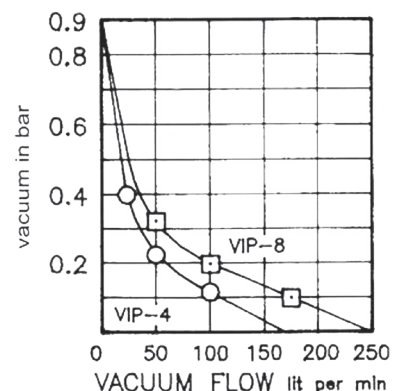
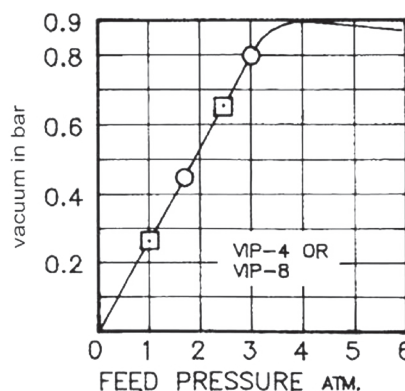
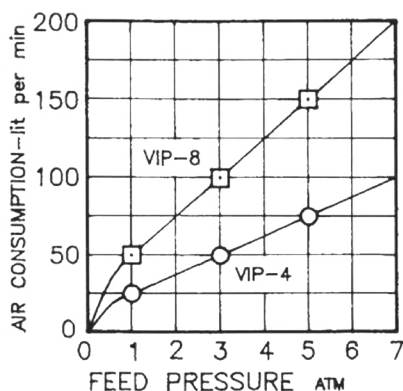

Power vacuum pumps - BCVIP12

A pneumatic ejector makes it possible to suck in air or any other gas contained in a closed chamber, in order to reduce the pressure. In the medical field, it is used at low working pressure (3.5 Bar). BCVIP ejectors are often used for handling materials or clamping small parts. They can be used with several suction cups. The flow rate of the BCVIP ejectors is high and the pressure is less sensitive to wear on the suction cup.



BCVIP12

Characteristics

Model	Air consumption	Max vacuum at 4 bar	Max vacuum flow	Working temperature	Noise level	Weight	Dimensions		
	(L/min)	(%)	(L/min)	(°C)	(db)	(Gr)	L	I	H
BCVIP12	240	90	590	20°C to +100°C	65 db	920	182	67	52

Materials

Epoxy painted AL, brass, silicon rub, neoprene, stainless steel.

Options

- Air silencer FFS 1/2"
- Kit energy saving pneumatic and electric 1/4"

Time in sec for evacuation of 1 lit to vac' level

Vacuum (bar)	0,1	0,2	0,3	0,4	0,5	0,6	0,7	0,9
BCVIP12	0,012	0,36	0,09	0,18	0,28	0,48	0,68	4,5

Induced air in lit per min

Vacuum (bar)	0	0,1	0,2	0,3	0,4	0,6	0,8
BCVIP12	580	350	210	98	75	37	11

Drawing BCVIP12 (mm)

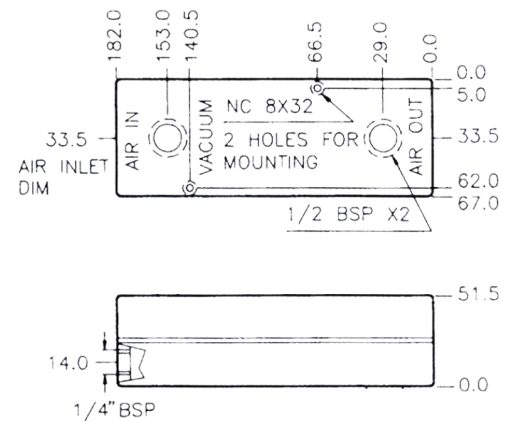

Data curves

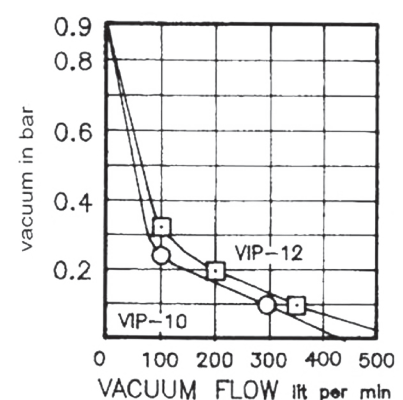
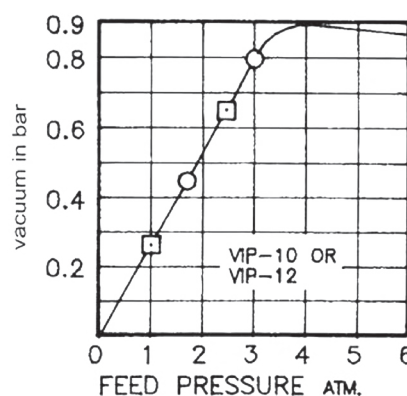
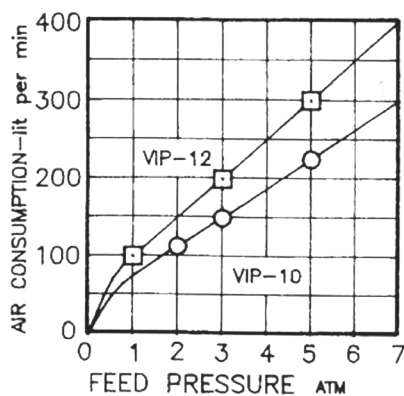



BCVILP16

Power vacuum pumps - BCVILP16

A pneumatic ejector makes it possible to suck in air or any other gas contained in a closed chamber, in order to reduce the pressure. In the medical field, it is used at low working pressure (3.5 Bar). BCVILP ejectors are often used for high throughput handling vacuum requirements in porous materials, cardboard and chipboard.

Characteristics

Model	Air consumption	Max vacuum at 6 bar	Max vacuum flow	Working temperature	Noise level	Weight	Dimensions		
	(L/min)	(%)	(L/min)	(°C)	(db)	(Gr)	L	I	H
BCVILP16	250-350	90	1050	-10°C to +100°C	75 db	2500	250	97	72

Materials

Epoxy painted AL, brass, neoprene, stainless steel.

Options

- Air silencer FFS 1 1/2"
- Kit energy saving pneumatic and electric 3/8"

Time in sec for evacuation of 1 lit to vac' level

Vacuum in ATM	0,1	0,2	0,3	0,4	0,5	0,6	0,7	0,8	0,9
BCVILP16	0,006	0,02	0,04	0,08	0,13	0,2	0,35	0,52	1,7

Drawing BCVILP16 (mm)

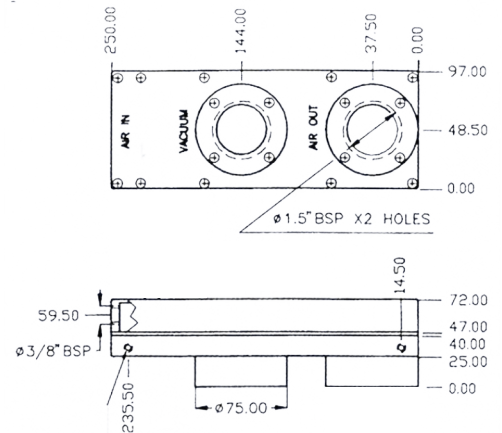

Vacuum flow lit per min, at ATM vacuum

Vacuum in ATM	0	0,1	0,2	0,3	0,4	0,5	0,6	0,7	0,8
BCVILP16	1050	680	420	260	180	150	100	50	25

Data curves

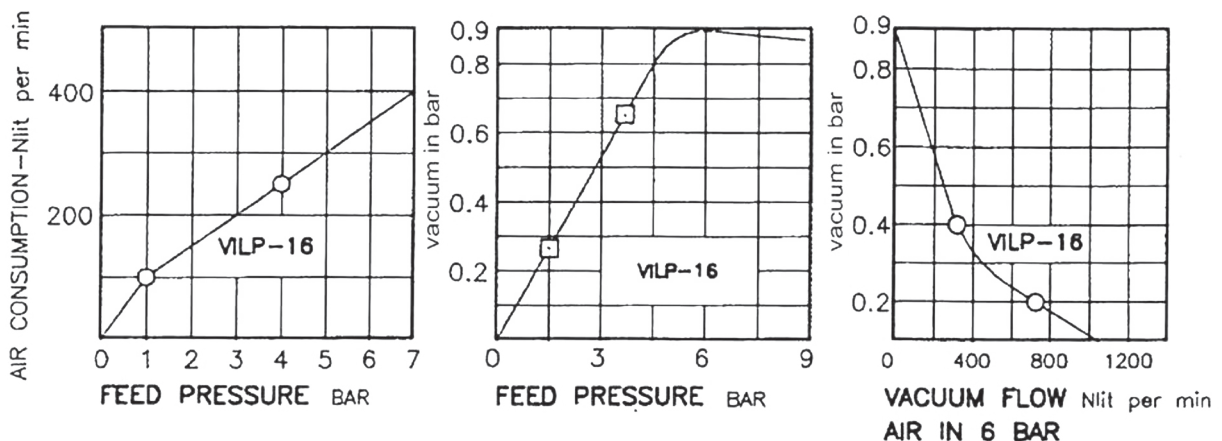



BCVILP32

Power vacuum pumps - BCVILP32

A pneumatic ejector makes it possible to suck in air or any other gas contained in a closed chamber, in order to reduce the pressure. In the medical field, it is used at low working pressure (3.5 Bar). BCVILP ejectors are often used for high throughput handling vacuum requirements in porous materials, cardboard and chipboard.

Characteristics

Model	Air consumption	Max vacuum at 6 bar	Max vacuum flow	Working temperature	Noise level	Weight	Dimensions		
	(L/min)	(%)	(L/min)	(°C)	(db)	(Gr)	L	I	H
BCVILP32	700	90	2100	de -10°C à +100°C	72 db	2800	250	97	90

Materials

Epoxy painted AL, brass, neoprene, stainless steel.

Options

- Air silencer FFS 1 1/2"
- Kit energy saving pneumatic and electric 3/8"

Time in sec for evacuation of 1 lit to vac' level

Vacuum in ATM	0,1	0,2	0,3	0,4	0,5	0,6	0,7	0,8	0,9
BCVILP32	0,003	0,005	0,01	0,03	0,05	0,08	0,13	0,23	0,85

Drawing BCVILP32 (mm)

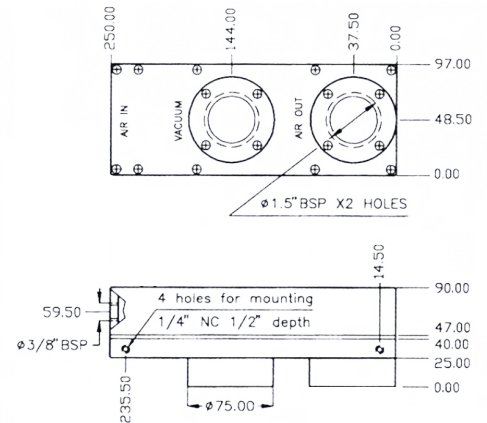

Vacuum flow lit per min, at ATM vacuum

Vacuum in ATM	0	0,1	0,2	0,3	0,4	0,5	0,6	0,7	0,8
BCVILP32	2100	1500	980	520	360	300	215	140	84

Data curves

