

## Liquid diaphragm vacuum pumps - BSHX26700

Head pump configurations have an integrated filter 400 µm  
**Applications** : Sampling, assay, analysis, rinsing and transfer



BSHX16700

### Characteristics

Free H2O Flow (L/min)	Maximum Pressure height (mH2O)	Maximum Pressure range (mH2O)	Suction Height (dry) (mmHg)	Dimensions (mm)			Mounting dimensions (mm)		Weight (Kg)
				L	W	H	L	H	
0,65	18	15	-350	132	65,5	84	25,5	36	0,58

### Electrical Data

Motor type	Rated Voltage	Start	Run	IP protection	Insulation class	Leadwire length (mm)	Motor life expectancy
		(Amps)	(Amps)				
Permanent magnet	12V dc	1,2 A	0,7 A	IP 20	Class E	300	3.000h (depending on application)
	24V dc	0,7 A	0,4 A				

### Vacuum pumps dimensions

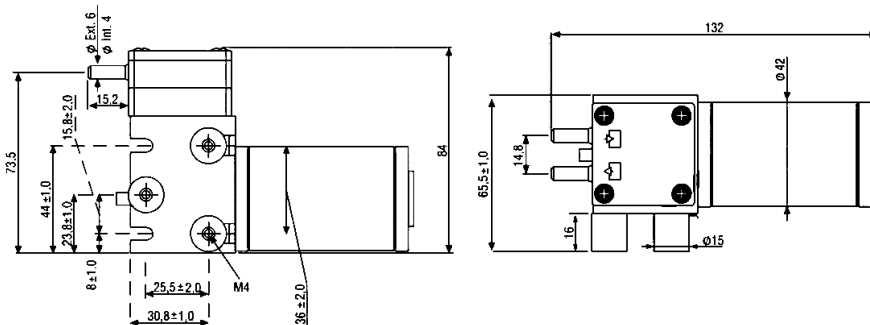

### Standard head configuration

Available	Head materials
Head Pump	PPS
Diaphragm	FPM
Valves	FPM
O-Rings	SILICONE

### Flow vs Pressure Curve

