

Air & Gas diaphragm vacuum pumps - BSHX26900

Head pump configurations have an integrated filter 400 µm

Applications : Sampling and pressurization

Characteristics

Models	Attainable vacuum	Free air flow	Max pressure	Working pressure range	Start up vacuum	Weight (Kg)	Dimensions (mm)			Mounting dimensions (mm)	
	(mbar)	(L/min)	(Bar)	(kPa)	(mmHg)		L	W	H	L	H
SERIES	-920	7	3	-92 up to 200	-550	1	163	76	84	94	36
PARALLEL	-800	14	1,5	-80 up to 150	-600						

Electrical Data

Motor type	Rated Voltage	Start	Run	IP protection	Insulation class
		(Amps)	(Amps)		
Direct Current	12V dc	1,7 A	1,0 A	IP 20	Class E
	24V dc				

Standard head configuration

Available	Head materials
Head Pump	PPS
Diaphragm	FPM
Valves	FPM
O-Rings	SILICONE

Vacuum pumps dimensions

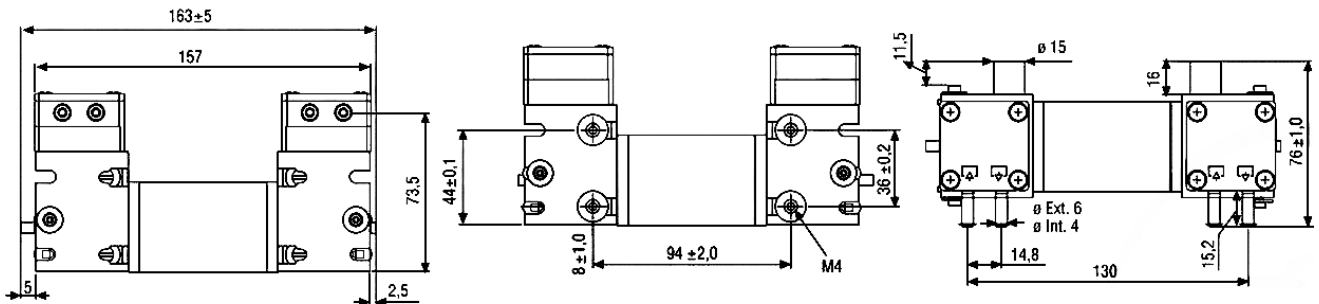

Flow vs Vacuum & Pressure Curves

