



BSHX28900

Air & Gas diaphragm vacuum pumps - BSHX28900

Head pump configurations have an integrated filter 400 µm
Applications : Sampling and pressurization

Characteristics

Models	Attainable vacuum	Free air flow	Max pressure	Working pressure range	Start up vacuum	Weight (Kg)	Dimensions (mm)			Mounting dimensions (mm)	
	(mbar)	(L/min)	(Bar)	(kPa)	(mmHg)		L	W	H	L	H
SERIES	-946	6	3,5	-94,6 up to 200	-600	1,8	193	76	98	138,5	36
PARALLEL	-813	12	1,6	-81,3 up to 160							

Electrical Data

Motor type	Rated Voltage	Max consumption	IP protection	Insulation class
		(Amps)		
Shaded pole	230V 50Hz	0,45 A	IP 00	Class B
	120V 60Hz	1,1 A		
	220V 60Hz	0,65 A		

Standard head configuration

Available	Head materials
Head Pump	PPS
Diaphragm	FPM
Valves	FPM
O-Rings	SILICONE

Vacuum pumps dimensions

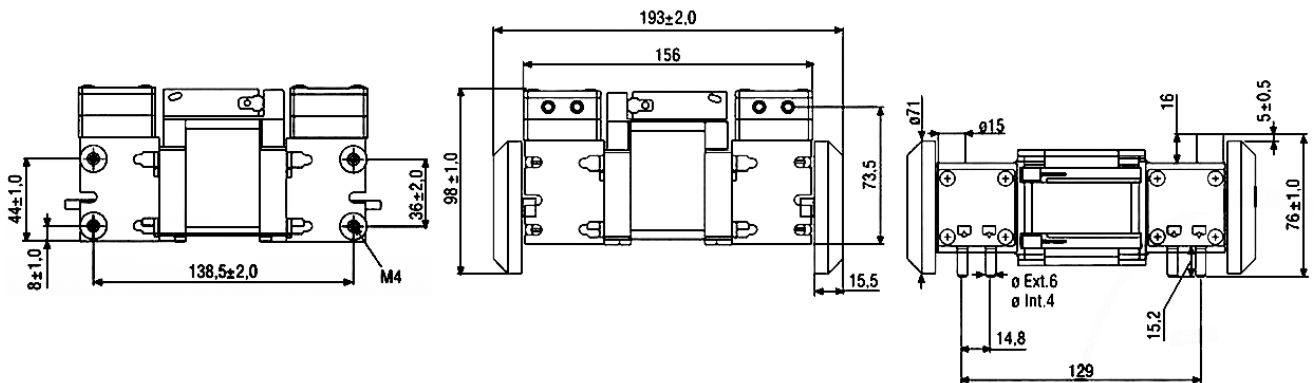

Flow vs Vacuum & Pressure Curves

